

RL75114-50K Rocker Column, Stainless Steel Welded Seal, IP67, NTEP 1:10,000 Class III L

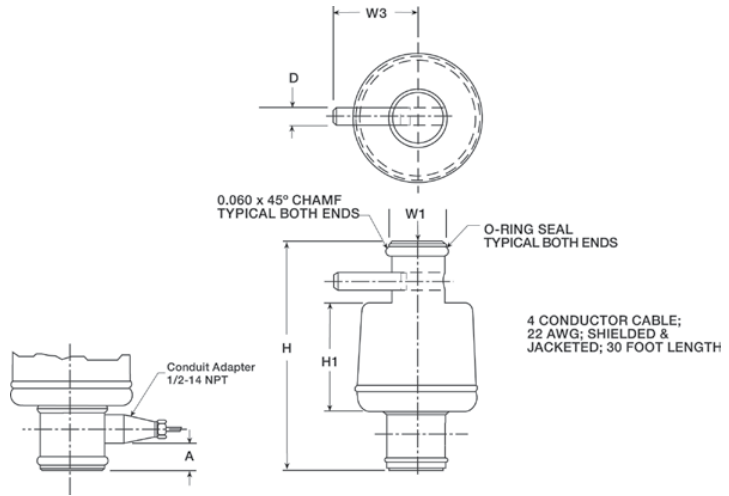

Picture is a representation of actual product



SPECIFICATIONS

<p>Full Scale Output: 1.8 mV/v nominal</p> <p>Output Resistance: 1000 ohms +/- 10</p> <p>Input Resistance: 1000 ohms</p> <p>Material/Finish: Stainless steel</p>	<p>Temperature: Compensated Range 14°F-104°F/-10°C-40°C</p> <p>Safe Overload: 150%</p> <p>Rated Excitation: 10V DC</p> <p>Combined Error: 0.025% full scale</p>	<p>Non-repeatability: .01% full scale</p> <p>Insulation Resistance: 1000 megohms</p> <p>Seal Type: Welded Seal IP67</p> <p>Cable Length: 30 ft/9 m</p> <p>Cable Diameter: .200 overbraided cable</p>	<p>Cable Color Code: Green..... + Excitation Black..... - Excitation White..... + Signal Red..... - Signal</p> <p>Warranty: Two-year limited warranty</p> <p>Approvals: </p>
--	---	---	---

DIMENSIONS

RATED CAPACITY	A	D	H	H1	W1	W3
lb/inches						
50,000 LE	.87	.38	7.56	2.82	1.46	2.18
kg/mm						
22,680.0	15.6	9.7	192.0	71.6	37.08	63.5

ORDER INFORMATION

LOAD RATING	PART #	PRICE
50,000 lb (22,679.6 kg)	88074	Consult
Replacement o-ring	92988	Consult
Spring pin	116181	Consult

Not interchangeable with Sensortronics 65114 - different mV/v

INTERCHANGEABLE PRODUCTS

MANUFACTURER	PART #	MODEL
Fairbanks	64166	LCFHR4020-2